

ColorWash 250 AT

ROBE



Crystal Casino - Russia



Eurovision 2007 - Finland



Geneva International Motor Show

This eagerly awaited fixture completes Robe's AT line of moving heads. A completely new optical system makes this fixture 50% brighter than its predecessor, the Wash 250 XT. New ultra smooth CMY colour mixing offers a fantastic spectrum of hues. A motorized zoom effect ranges from 8° - 32° and the extremely silent cooling system and movement make this fixture a superb choice for TV and theatre.

The colour wheel offers 6 saturated colours + open, using Robe's renowned SLOT&LOCK system. Frost filter and a beam shaper are available on the effect wheel. As with all other Robe AT moving heads, 16-bit resolution is available for movement, colour wheel positioning and dimming.

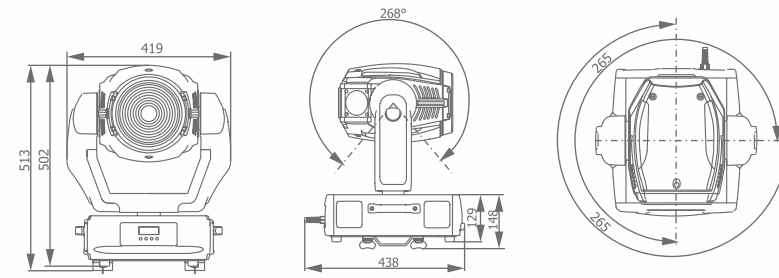

Photometric Diagrams

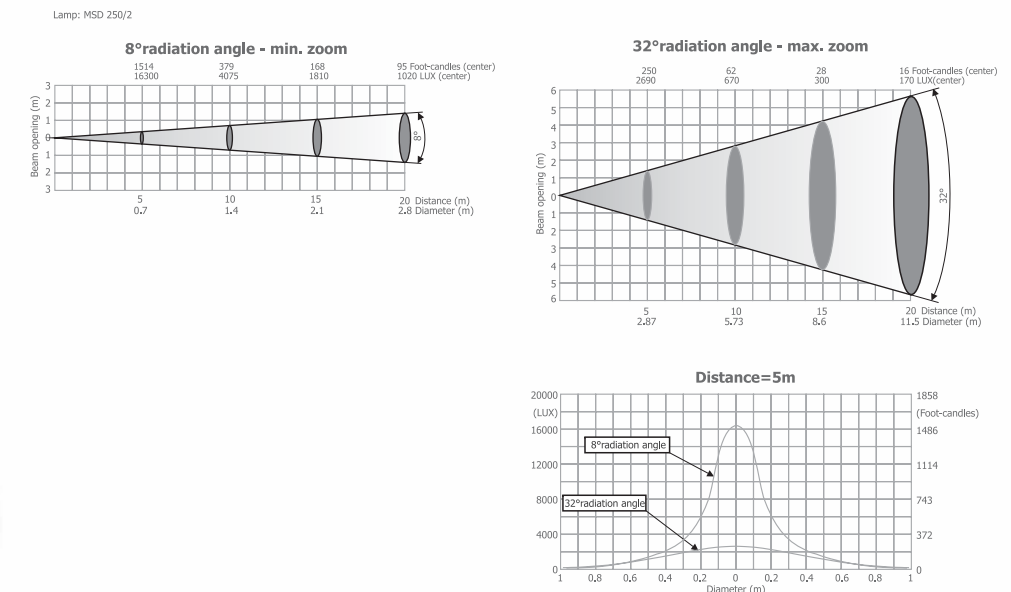

Product information

ColorWash 250 AT

Source:

- Lamp: Compact high-pressure metal halide lamp
- Base: GY9.5
- Approved model: Philips MSD 250/2
- Control: Automatic and remote on/off
- Ballast: Magnetic

Electrical Specification:

- Wiring options - EU model: 208/230/240V AC, 50/60Hz
- Wiring options - US model: 100/120/208/230/240V AC, 50/60Hz
- Power consumption: 405 VA at 230V

Mechanical Specification:

- Height: 513 mm (20.2")
- Width: 419 mm (16.5")
- Depth: 438 mm (17.2")
- Weight - EU model: 20.5 kg (45.2 lbs),
US model: 23.5 kg (51.8 lbs)

Thermal:

- Maximum ambient temperature: 45°C (113°F)
- Maximum surface temperature: 70°C (158°F)

Control & Programming:

- Protocol: USITT DMX-512
- Control channels: 16, 18, 20
- DMX channels: 4 protocol modes
- Built-in demo sequences
- Display: 4-digit LED display
- Pan/Tilt resolution: 16-bit
- ColorWheel positioning: 8- or 16-bit
- Zoom: 8- or 16-bit
- Dimmer: 8- or 16-bit
- Master/slave operation
- Movement control: tracking and vector
- Built-in analyzer for easy fault finding
- Data in/out: Locking 3-pin XLR & 5-pin XLR

Electromechanical Effects:

- Cyan: 0 - 100%
- Magenta: 0 - 100%
- Yellow: 0 - 100%
- Colour wheel: 6 replaceable "SLOT&LOCK" dichroic filters + open
- Effect wheel: Beam Shaper rotated by 90°, Frost Filter
- Dimmer/Shutter: Full range dimming and variable strobe effect
- Zoom: Motorized zoom effect 8° - 32°
- Pan: 530°
- Tilt: 268°

Rigging:

- Mounting points: 4 pairs of ¼ -turn locks
- 2x Omega brackets with ¼ -turn quick locks



ROBE

w w w . r o b e . c z

HQ & Factory: ROBE Lighting s.r.o. ■ Házovice 2090 ■ 756 61 Rožnov p. Radhoštěm ■ Czech Republic ■ Tel.: +420-571-751 500 ■ Fax: +420-571-626 337 ■ E-mail: robe@robe.cz
UK: ROBE UK Ltd. ■ Northampton, UK ■ Tel.: 01604 741000 ■ E-mail: info@robeuk.com ■ America: ROBE Lighting Inc. ■ Florida, FL, USA ■ Tel.: (954) 615-9100 ■ E-mail: info@robelighting.com

South-East Asia: ROBE S.E.A. ■ Singapore ■ Tel.: +65-8118 6665 ■ E-mail: info@robe-sea.com

September © 2007 Robe Lighting s.r.o. All specifications subject to change without notice.

ColorWash 250 AT



ROBE